

Aeroflex PXI 3000:
**A Success Story in the Realm of
RF Communications Test**

PXI Product Backgrounder

Aeroflex 3000 Series

November 2009

Table of Contents

- [Aeroflex and PXI: A Success Story in the Realm of RF Communications](#) 3
 - [Aeroflex and PXI Making Waves in RF Testing](#) 5
 - [Aeroflex Strategic Product Development Overview](#) 6
- [A Brief Overview of PXI](#) 7
 - [Instrumentation Bus History](#) 9
 - [Key Points for Standalone Bus Technologies](#) 11
 - [Modular versus Standalone Instruments](#) 11
- [Benefits of PXI](#) 12
 - [Comparison of Test Platforms](#) 13
- [PXI 3000 Hardware Modules](#) 14
- [The PXI Standard Software Architecture](#) 15
- [PXI 3000 Software Architecture](#) 16
 - [PXI Module Software](#) 16
 - [Measurement Suites](#) 17
- [Testing Capabilities for Wireless Standards](#) 20
- [Applications Served by the Aeroflex 3000 Series](#) 21

Aeroflex and PXI: A Success Story in the Realm of RF Communications

As part of its strategy to provide customers with flexible and cost-effective test systems, on October 2003 Aeroflex launched the 3000 Series, a PXI-based modular test suite for mobile phone and general-purpose wireless test.

Aeroflex was the first company to bring to market high-performance RF test capability in PXI, an inherently flexible and cost-effective platform. With a history of over 70 years in test and measurement system development, Aeroflex extended its RF know-how into the PXI instrumentation market.

Today the PXI 3000 modular RF test system is well established and has been proven in production and R&D sites worldwide. The flexibility and speed benefits of the platform have been the source of its success along with the broad support and high level of customer care provided by Aeroflex. The applications development support provided by Aeroflex has guaranteed the benefits of the platform are exploited to the fullest.

The Aeroflex 3000 Series now encompasses 15 PXI RF modules and supporting applications for signal generation and signal analysis that meet the specific requirements for a wide range of mobile communication standards. Applications include automated measurement of parametric performance of terminal transmitter and receiver characteristics, terminal TX and RX alignment and performance characterization for manufacturing, and research and development.

In addition, the Aeroflex 3000 Series expands PXI's speed and modularity into the realm of general-purpose wireless testing—the 3020 Series of signal generator modules can be used for continuous wave (CW) and digital signal generation for general purpose wireless device testing and characterization.

The new Aeroflex PXI 3000 wireless test suite includes a comprehensive set of components enabling adopters to build a system that matches today's test requirements while maintaining scalability for future applications.

The following table lists the hardware modules and software that make up the PXI 3000 Series product portfolio.

PXI 3000 Series
PXI RF Synthesizer
3010/3011 PXI RF synthesizers
PXI 3030 Series RF Digitizers
3030A PXI 3 GHz RF digitizer
3030C PXI 3 GHz wideband RF digitizer
3035 PXI 6 GHz RF digitizer
3035C PXI 6 GHz wideband RF digitizer
PXI 3020 Series Digital Signal Generators
3020A PXI 2.7 GHz RF signal generator
3020C PXI 3 GHz RF signal generator
3021C PXI high power 3 GHz RF signal generator
3025 PXI 6 GHz RF signal generator
3025C PXI 6 GHz RF signal generator
3026C PXI high power 6 GHz RF signal generator
Aeroflex 3060 Series RF Combiners
3060 PXI RF Combiner 2.7 GHz
3065 PXI RF Combiner 6 GHz
Aeroflex PXI Controllers and Chassis
3000/3000B 8 slot PXI chassis with/without touch screen LCD panel display
20 slot PXI chassis with PCI/PCIe interface card to external controller (82547/8)
18 slot PXI chassis with/without PCI interface card to external controller (82545/65)
3001B/3001C PXI controller modules with single/dual core CPU
Aeroflex PXI 3000 Software
IQCreator [®] waveform creation tool
PXI Studio application software
GSM/EDGE measurement suite
UMTS/HSUPA uplink measurement suite
LTE FDD measurement suite
CDMA2000/1xEV-DO reverse link measurement suite
WLAN measurement suite
WiMAX OFDMA measurement suite
Bluetooth measurement suite

Aeroflex and PXI Making Waves in RF Testing

Early after its introduction to the market, the Aeroflex PXI 3000 Series had been adopted by leading players in the mobile communications industry. From traditional vertically-integrated handset manufacturers to leading semiconductor and RFIC manufacturers, PXI has been providing significant performance enhancements to multiple players in the industry. Hence, PXI module development has focused and continues to focus on digital and analog communications device testing at the manufacturing stage.

The breadth of applications however extends further, the Aeroflex PXI 3000 solution has also been used thoroughly in research and development environments see *Box 1: PXI 3000 as a top-performing solution in Research and Development*. Its flexibility, small size and low cost prove equally attractive to research and development labs in many fields of RF applications.

Box 1: PXI 3000 as a top-performing solution in Research and Development

At Chalmers University in Sweden, the Aeroflex PXI 3000 Series supports developments on quantum computing within the Microtechnology and Nanoscience department (MC2). Cutting-edge research requires high accuracy and performance to guarantee the validity of measurements and create the practical solutions of tomorrow. Bandwidth capabilities in addition to level accuracy and low cost of the PXI 3000 marked the advantage that made the switch from rack and stack instruments possible.

Compatibility of PXI 3000 with multiple off-the-shelf software environments allowed the Quantum Device Physics laboratory to use MATLAB and Igor Pro, a scientific analysis software, to program their own measurement solution. The vast support received from the Aeroflex engineering teams enabled MC2 to set up their fully customized measurement system in minimal time from the birth of this successful and very fruitful business relationship.

Chalmers University's MC2 is globally recognized as the leading entity in quantum computing research. They made the decision to use Aeroflex as the provider of choice in their development work. Following their positive experience with PXI 3000, interest from other top research centers has arisen from all corners of the world, from Helsinki to Sydney.

The team at Chalmers have found the PXI 3000 to be such a flexible tool for research purposes that they have already expanded their base to 10 systems leveraging their research capacity four-fold and lowering investment costs. Other departments at the university have been contemplating the possibility of using the PXI 3000 following the endorsement from the Quantum Device Physics laboratory. PXI 3000 is fit for use in a diverse number of applications and its flexibility has been demonstrated in development and manufacturing environments.

Aeroflex Strategic Product Development Overview

The Aeroflex PXI product development plan is the result of intensive technology investigation and research into customer needs in the RF communications test market. Working closely with its broad customer base, Aeroflex develops modules and instruments using PXI, so customer needs can be met in a timely and cost-effective way.

In response to market needs and future developments, the Aeroflex strategy calls for the phased introduction of a new range of PXI modules, software application libraries and test instrument configurations. Each Aeroflex module has been carefully defined to maximize reuse potential for development of future modules, extending the economic life of the investment made on the test instruments. Wherever necessary, Aeroflex will produce customer-specific solutions for wireless applications.

In an effort to keep up to date with technological innovations in the field of RF communications, Aeroflex continually monitors developments in the telecommunications industry. Based on market feedback and production trends, Aeroflex develops new software applications to maximize performance of the PXI 3000 in production environments. Due to the common interest in improving performance of PXI 3000 in the field and the open nature of the software platform, Aeroflex works in conjunction with customers to develop new solutions that better satisfy end user requirements.

A Brief Overview of PXI

PXI derives its name from the PCI eXtensions for Instrumentation specification that defines a rugged personal computer-based bus as the basis for a common platform for measurement and automation systems. PXI uses the high-speed Peripheral Component Interconnect (PCI) bus combined with the rugged, modular Eurocard mechanical packaging of CompactPCI and adds mechanical, electrical and software features that define complete systems for test and measurement, data acquisition and manufacturing applications. These extensions make it easy for end users and integrators to quickly build open, multi-vendor measurement and automation systems.

PXI modules can be either 3U or 6U (fig A) Eurocard formats and use high performance IEC connectors (IEC-1076). Forced air cooling and environmental testing requirements are specified making PXI suitable for industrial applications.

The PXI standard adds a dedicated system reference clock, PXI trigger bus, Star trigger bus and slot-to-slot local bus for advanced timing and synchronization (figure B). The 10 MHz reference clock along the backplane provides a common reference for all modules.

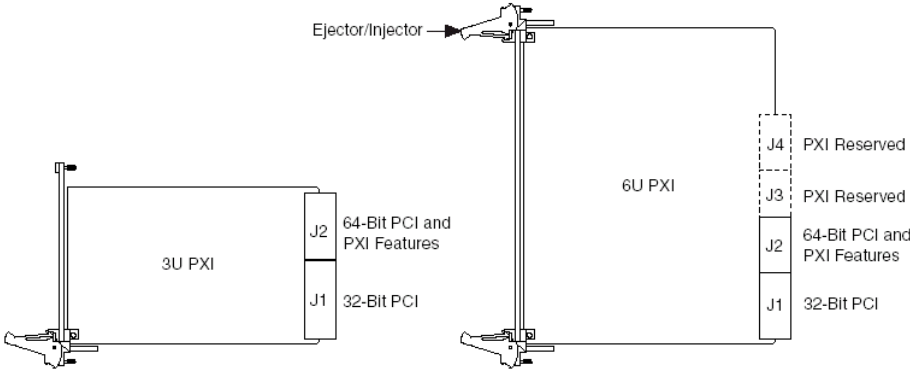

Figure A – PXI Eurocard format options for 3U and 6U

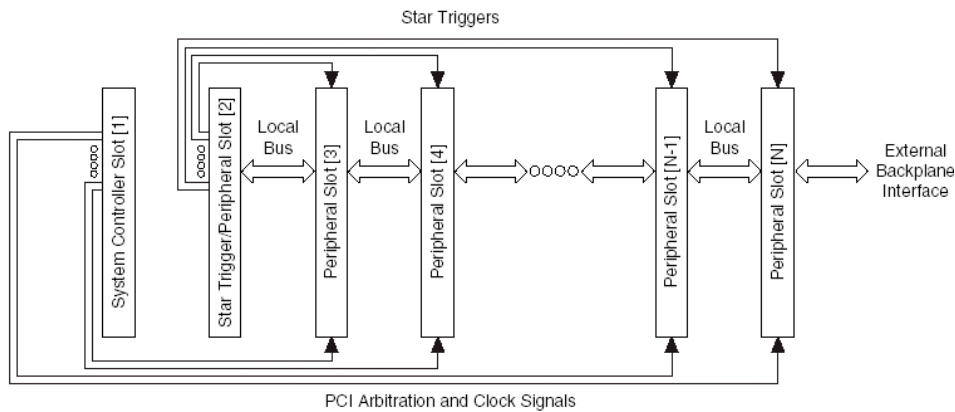

Figure B; PXI local bus, Star trigger bus extensions

PXI was designed to bridge the gap between desktop PC systems and high-end VXI and GPIB bus systems. While standard PCs offer a very low-cost option for instrumentation systems, they fail to meet many of the needs of industrial and embedded applications. VXI and GPIB systems meet the specific needs of instrumentation users, but are often too large and expensive.

While PXI extends CompactPCI, it also maintains complete interoperability so the user can deploy any CompactPCI-compliant product in a PXI system and vice versa. PXI extensions also leverage off other standard technologies, such as Windows[®] software, VXI timing and triggering, VXIplug&play instrument drivers, and international environmental testing standards to deliver a powerful and affordable system.

The PXI Systems Alliance (PXISA), formed in 1997, supports PXI. Its membership reached 59 suppliers worldwide in 2008 offering more than 1150 different PXI products. Aeroflex is a sponsor member of the PXISA demonstrating the company's full commitment to the development and promotion of the PXI standard.

The role of the PXISA is to promote the PXI standard, ensure interoperability and maintain the PXI specification. The PXI specification is currently released at version 2.2 –September 22, 2004. The PXI-express standard initially released in 2005 is an extension to the current PXI standard that enables the backplane to

achieve data throughput of 6 GBytes/sec in each direction. PXI-express chassis are backwards compatible with PXI-1 cards but PXI-express cards cannot be used in a PXI-1 chassis.

Instrumentation Bus History

Instrumentation bus technology has evolved over the past 30 years. It falls into two main categories, standalone and modular. The main standalone bus technology during this time has been General Purpose Interface Bus (GPIB) and, to a lesser degree, RS-232, with more recent emergence of Ethernet, Universal Serial Bus (USB) and IEEE-1394 (Firewire).

Modular bus technologies have evolved from VME into VXI and more recently from PCI into CompactPCI and now PXI. Modular bus technology offers many advantages over older bus standards. However, they must overcome an enormous installed base of users worldwide.

Instrumentation Bus Milestones

	Hardware Milestones	Software Milestones
1975	GPIB (HPIB) Later to become 488.1 Defines Parallel Bus physical, mechanical, electrical parameters	Over 5 million GPIB cable instruments are currently deployed
1987	VXI Modular architecture based on VME	GPIB 488.2. Software structure defined and formalized
1990		SCPI, Standardized Command Set for Programmable Instruments
1993		Formation of VXI plug&play Alliance to standardize instrument driver software
1995	Emergence of instrumentation with USB and ENET connectivity	
1997	Formation of PXI Systems Alliance to standardize and promote PXI	
1998		Formation of IVI foundation
2003	HS488. Higher speed GPIB increasing data rates to 8 Mbyte from 1.5 Mbyte	PXI Software Specification Rev 2.1 introduced
2004	PXI-1 Hardware Specification Rev. 2.2 introduced LXI standard is introduced	
2005	PXI- express Hardware Specification introduced	
2007		
2008	LXI Standard reaches Revision 1.3	PXI-2 Software Specification Rev. 2.3 introduced
2009	PXI MultiComputing Hardware Specification Rev. 1.0 introduced	PXI MultiComputing Software Specification Rev. 1.0 introduced

An estimated 600,000 PXI modular instruments and related devices deployed

Key Points for Standalone Bus Technologies

	GPIB	RS-232	Ethernet	USB	IEEE-1394
Speed	1.5 Mbyte to 8 Mbyte (HS488)	28.8 kByte	1.25,12.5 and 125 Mbyte	1.5 Mbyte (USB V1.0) 12 Mbyte (USB V1.1) 60 Mbyte (USB V2.0)	100 Mbyte
Products Available	>100,000	>10,000	<100	<100	<10
Latency	Low	Low/Medium	High	High	High
Max number of devices	14	1	No limit	127	63
Max cable length	20m	15m	No limit	30m	4.5m
Connectors	Industrial	Industrial/ Consumer	Consumer	Consumer	Consumer
Triggering	Minimal	Minimal	Minimal	Minimal	Minimal

Modular versus Standalone Instruments

Modular instruments offer many advantages over standalone instruments—all of which are relevant to automated measurement applications associated with design validation and manufacturing test.

Modular Instruments	Standalone Instruments
Open/multi-vendor	Closed / Proprietary
User-defined	Vendor-defined
Easy integration	Limited integration
Scalable	Limited expandability
Standard SW model	Proprietary SW model
Pay for what you NEED	Pay for what you GET
Reconfigurable	Fixed configuration

Benefits of PXI

PXI represented a major breakthrough in test platforms. Not since the introduction of GPIB had there been such a surge of industry activity and market adoption. Over ten years into its existence, PXI remains one of the fastest growing technologies in the market. According to Frost and Sullivan, the PXI market experienced a growth rate of 23.5 percent over 2007 and the trend in growth is forecasted to remain strong.

PXI modular instrumentation delivers a PC-based, standardized, high-performance measurement and automation system at an affordable price.

Open standard, multiple vendors: PXI is an ideal platform for automated test systems. Multiple vendors provide a wide array of instrumentation modules, with hundreds of suppliers providing thousands of PXI products.

Small, compact, rugged package: For industrial applications that require embedded control, PXI and a real-time operating system provide a perfect solution. PXI delivers high performance in small, rugged packaging, making PXI an ideal deployment platform for in-vehicle applications.

Large selection of PXI instruments and modules: Oscilloscopes, multi-meters, waveform generators, RF analyzers and switch multiplexers are just some of the many instrumentation modules available in PXI today.

Tight integration: You can achieve a higher degree of integration between your test instruments than ever before with PXI. PXI offers simple ways to integrate GPIB, VME, VXI, and serial instruments into your system.

Low cost: Because of their small size and tight integration, PXI modules and systems are often lower in cost than alternative technologies.

Aeroflex views PXI as the ideal architecture for rapid product and custom solution development. This has become an essential requirement to remain competitive and satisfy market needs in fast evolving communications development and manufacturing applications.

Comparison of Test Platforms

	Standalone	Modular		
	GPIB	VXI	PXI	LXI
Speed	1 MB (488.2) to 8 MB (HSS488)	40 MB to 80 MB (VME64)	132 MB	10 MB/s to 10GB/s
Timing and Synchronization	None	Defined		
Product Availability	>10,000	>1,000	>1,500	1000's
Form Factor	Large	Medium	Small / Medium	Multiple
Standard Software Framework	None	VXIplug&play		
Modular	NO	YES		
EMI Shielding	Optional	Defined	Module Specific	Instrument Specific
System Cost	High	Medium – High	Low - Medium	Low - Medium

PXI 3000 Hardware Modules

Since phase one Aeroflex addressed the basic building blocks for RF communications test systems in PXI development. In order to exploit the benefits of PXI, RF test system developers required first to have their needs met for performance and functionality, particularly in the areas of RF signal stimulus and RF signal analysis.

The RF synthesizer has been used by Aeroflex since its inception as the underlying module for using PXI for RF instrumentation based upon the patented Fractional-N synthesizer. The 3020 Series RF signal generator modules are used in conjunction with the 3010 RF synthesizer to provide modulation and waveform generation, RF levelling and frequency tuning from 100 kHz to 6 GHz.



Figure C: The PXI 3020 Series RF Signal Generators

The 3030 Series RF digitizers provide frequency down conversion and high dynamic range analog to digital conversion for measurement and real time applications. The 3030 Series RF digitizers are also used with the 3010 RF synthesizer, which provides the tuneable local oscillator (LO).

Finally, the 3060 Series RF combiner modules provide UUT interfacing to the 3020 and 3030 Series modules for mobile radio and RF component test applications. A number of combiner modules have been designed to accommodate the requirements of mobile handset manufacturers.

The PXI Standard Software Architecture

The software requirements of PXI modular instrumentation are largely defined by the PXI software specification and the VXIplug&play specification. The PXI software specification is managed by the PXI Systems Alliance of which Aeroflex is an active member. The VXIplug&play specification is managed by the VXIplug&play Systems Alliance, which in turn is managed by the Interchangeable Virtual Instrument (IVI) Foundation, a not-for-profit organization. The goal of IVI is to maximize the interchangeability of test system instrument hardware without the need for software redevelopment.

The PXI software specification defines standard frameworks for PXI systems. The specification stipulates that the module device driver software must run within a given framework, where the framework is based on the 32-bit Microsoft Windows® operating systems, covering Windows® 2000, XP and Vista. A recommendation of the PXI software specification is for PXI module compatibility with well-established development environments including National Instruments'® LabVIEW and LabWindows/CVI, Microsoft Visual C/C++ and Visual Basic.

The PXI modular hardware is configured and controlled by a device driver implemented using the Virtual Instrument Software Architecture (VISA). The VISA architecture is an I/O software standard, defined by the VXIplug&play specification, and adopted for PXI as well as GPIB, VXI, VME and serial instrumentation. National Instruments'®, NI-VISA is the version of VISA used in the Aeroflex PXI 3000. Using VISA promotes interoperability of the software.

PXI 3000 Software Architecture

The PXI 3000 software architecture reflects the same degree of modularity as its hardware components. The major components can be identified in the diagram below as:

- PXI module software
- Measurement suites
- PXI Studio GUI application

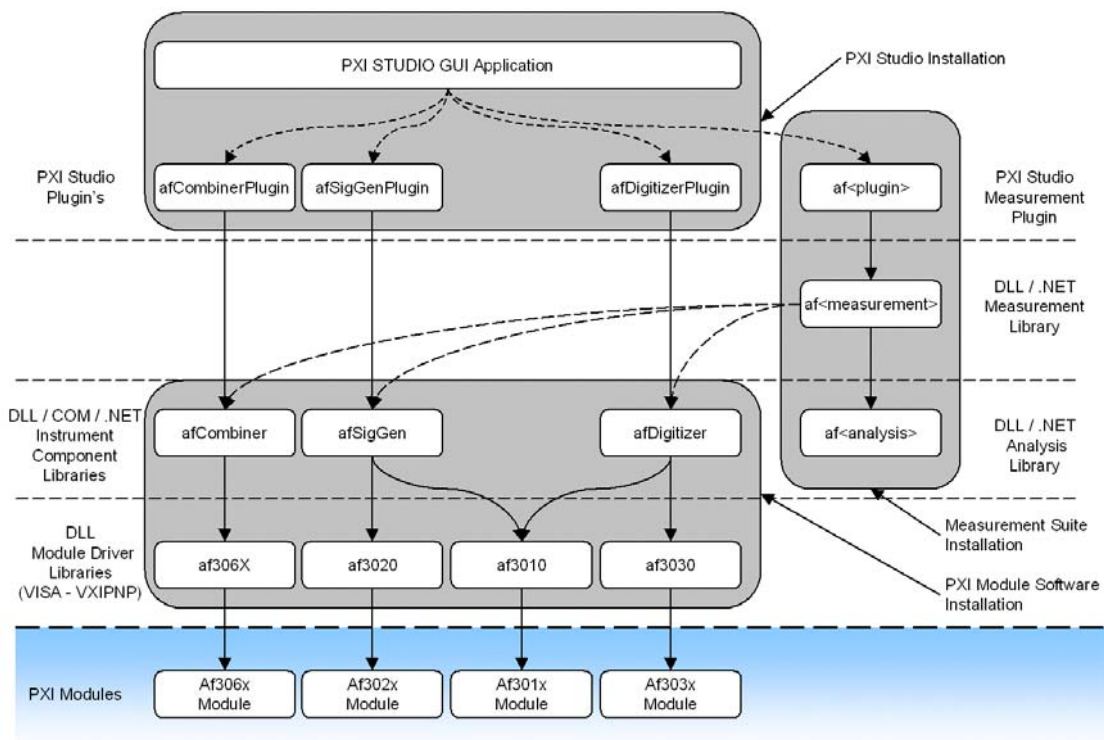

Aeroflex 3000 Series PXI Modules - Software Architecture Overview

PXI Module Software

PXI module software relates to the lower level of programming and directly interacts with the underlying hardware. PXI module software is comprised of:

- Module driver libraries
- Instrument component libraries

Module Driver Libraries

A module driver library is a low level library for use within the standard frameworks and software development environments described in the previous section. These libraries control the module using DLL software interfaces. The following module drivers are included with every PXI system: af3010, af3020, af3030, af306X. Since these closely relate to operations and control at hardware level, most users will not program with the module driver libraries, but instead use the instrument component libraries.

In addition to the module driver DLL and source, soft front panels are provided for each module. The panel allows the end-user to test the module and perform basic operations.

Instrument Component Libraries

An instrument component library is a higher level library that makes use of one or more PXI modules (using its module driver library) to create an instrument. The instrument component library use DLL, COM and .NET assembly interfaces. It provides control of all modules that make up the 'instrument' and look after any interactions between them. For example, the afSigGen instrument component library uses the following:-

- af3010 module driver library
- af3020 module driver library

Measurement Suites

The portfolio of Measurement Suite software is in continual expansion as technology evolves and the wireless market adopts new standards. The Spectrum measurement suite is provided as standard with every PXI 3000 system that is shipped. A number of optional measurement standards can be added to expand the capabilities of the PXI 3000 platform as the need arises. Measurement Suites will be

further described under the section titled “*Testing Capabilities for Wireless Standards*”.

A measurement suite installer will usually contain the following:

- Analysis library
- Measurement library
- PXI Studio plug-ins

Both the analysis and the measurement libraries support DLL and .NET assembly software interfaces

Analysis Libraries

An analysis library is a hardware independent low level library that performs DSP style calculations to analyze the supplied IQ data and generate test results. The user has to control the test hardware in a suitable way and then pass data to the library for analysis. When using analysis libraries, users will setup sample rates, number of samples to capture, level corrections, spectrum stitching, low level hardware settings, low level analysis settings and ARB file selection among other parameters.

Measurement Libraries

A measurement library is a hardware dependant high level library that performs user requested measurements. The library simplifies the use of all the modular software and hardware components by performing all of the actions required for the measurements using the most optimal settings and return the results. It uses the relevant instrument component libraries to control the hardware and the relevant analysis libraries to perform the analysis to calculate the required measurement results. A measurement library would make use of more than one instrument component and/or analysis library.

PXI Studio Plug-ins

The PXI Studio plug-ins, with PXI Studio, provides an easy to use Windows® GUI application for the associated measurement library. This allows the functionality of the measurement library to be used interactively without writing any code.

The Plug-ins provide the instrument with an intuitive interface to perform measurements often implemented following the relevant body's test specifications. Measurements are presented as numerical values, traces or pass/fail indications.

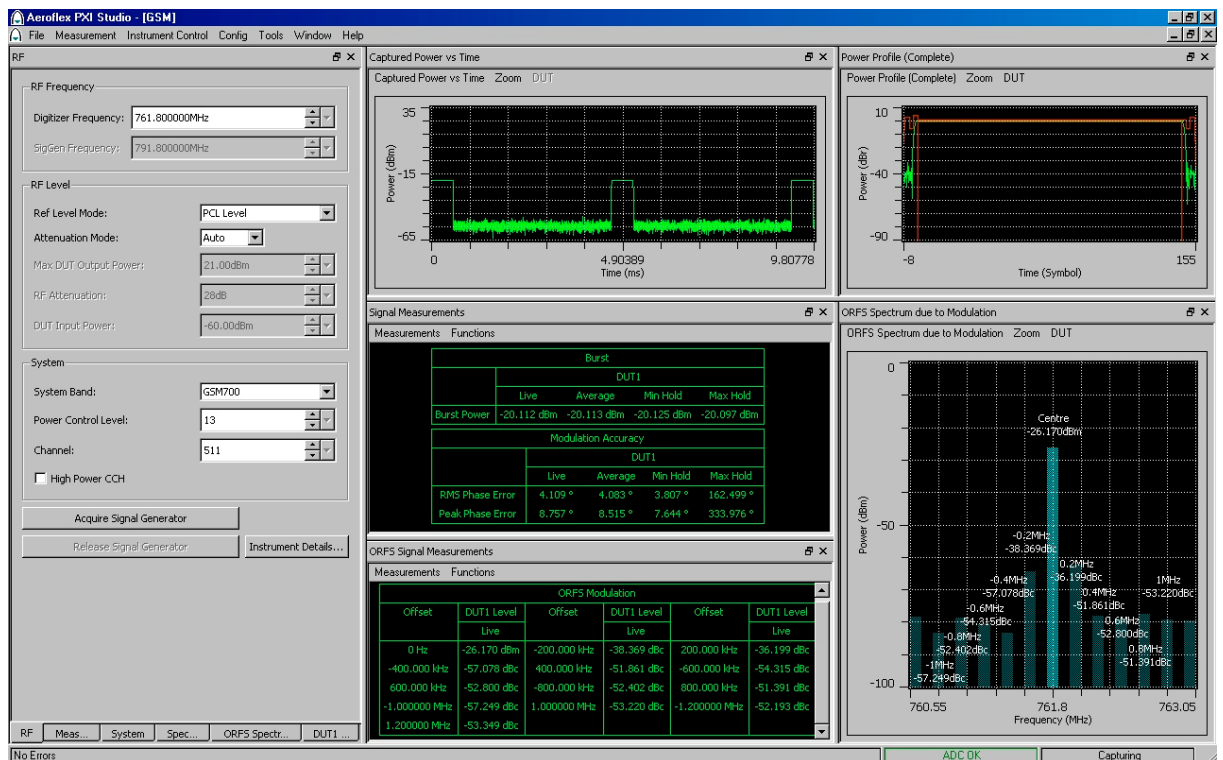

Figure D: PXI Studio screenshot for GSM/EDGE measurement suite

Since many of the elements of the PXI software are developed as open libraries, Aeroflex software provides an environment that offers modularity, reuse and expandability.

Testing Capabilities for Wireless Standards

The PXI 3000 Series feature measurement analysis capabilities for various wireless standards exposed through the relevant Measurement Suites. Each measurement suite is independent from the other but follows the same structure described in the section titled “PXI 3000 Software Architecture”.

The PXI 3000 is aimed at providing full coverage of all wireless standards supported in mobile communication devices. Test coverage includes wireless connectivity standards such as Bluetooth and WLAN which are increasingly integrated into all types of wireless devices. Legacy mobile communication standard testing such as GSM/EDGE, UMTS and CDMA2000/1xEV-DO continues to be thoroughly supported. 3.5G and 4G technologies are also immediately available for use with PXI 3000 including WiMAX, LTE and TD-SCDMA.

Support for this broad range of wireless standards enables time savings in multi-interface mobile handset production tests. Few production test instruments, if any, can provide such broad test coverage while maintaining performance levels in a compact presentation with reasonable pricing.

Applications Served by the Aeroflex 3000 Series

The PXI architecture is primarily suited to automated measurement systems used in design validation and manufacturing test. The Aeroflex PXI modules are a direct fit for these markets—they have functionality and performance tailored to the needs of mobile terminal measurement where speed, good RF performance, repeatability and accuracy are key drivers.

Applications for the Aeroflex 3000 Series include automated measurement of parametric performance of terminal transmitter and receiver characteristics. This includes power analysis, spectral analysis and modulation analysis of analog and digital transmitter signatures, together with various wanted and unwanted stimulus for receiver sensitivity measurement. The 3000 Series also services the needs of component testing, whether it is a simple RF component or a highly integrated RF integrated circuit (RFIC).

In manufacturing, the 3000 Series is used for terminal TX and RX alignment and performance characterization prior to final assembly. The 3000 Series modules harness the speed of PXI by incorporating List Mode and Fast Sequence Tuning features to accelerate hardware setup times and DUT calibration. Implementation of application-specific multithreaded algorithms enables the concurrent test of multiple devices transferring speed advantages to the production line.

In R&D, the 3000 Series modules will serve as RF transducer functional blocks in full-blown system simulators. By utilizing the power real-time input/output features of both the 3020 digital RF signal generator and 3030 RF signal analyzer with external PXI-based DSP/FPGA modules, full Layer 1 coding and decoding can be performed and then used in conjunction with system protocols to test terminal functionality.